



Canadian Karting Regulations

Book 2 Technical Regulations

To be read and applied in conjunction with:
Canadian Karting Regulations Book 1, Sporting Regulations

Effective January 1, 2026

GDS ASN CANADA IS THE GOVERNING BODY OF MOTORSPORT IN CANADA

Appointed by

FEDERATION INTERNATIONALE DE L'AUTOMOBILE

Copyright © 2026 GDS ASN CANADA

These regulations govern all National Competitions sanctioned by GDS ASN CANADA.

Published by:

GDS ASN CANADA

200 Circuit Gilles-Villeneuve

Montréal, Québec, H3C 1A9 Canada

(514) 350-8203

info@asncanada.ca

<https://www.asncanada.ca>

All enquiries regarding these Regulations should be addressed to:

GDS ASN CANADA

Kart racing is a dangerous sport.

These regulations are intended to assist in the conduct of competitions and to further general safety. They are a guide, and in no way a guarantee against injury or death to participants, spectators or others.

No express or implied warranties of safety or fitness for a particular purpose shall be intended or result from publication of or compliance with these Regulations.

Participants are encouraged to inspect the racing facilities and to bring to the attention of the organizers and officials anything that is of a concern to their personal safety. If a participant is not comfortable with the facility they should consider withdrawing from the event. If the driver is under the age of majority, then the parents, guardians and/or handlers should inspect the facilities as above.

Karting Organizations, Clubs or Series may adopt these Technical Regulations and the Sporting Regulations in Book 1 for use within their own competitions.

Changes to the Regulations for 2026 indicated in a narrow bold font.

.

Table of Contents

1.	THESE TECHNICAL REGULATIONS	5
2.	PARTS, COMPONENTS, MEASUREMENTS	5
3.	EQUIPMENT ENTRY REGULATIONS	5
	3.1. Definition of a Kart	5
	3.2. Briggs & Stratton, Rok and Rotax have their own technical specifications	6
	3.3. Repairs or Replacement After Technical Marking	6
	3.4. Exchanging of Equipment	6
4.	PRE-RACE TECHNICAL INSPECTION	7
	4.1. Technical Inspection Self-Declaration	7
	4.2. Technical Inspection Sticker	7
5.	TECHNICAL MARKING PROTOCOL.....	7
	5.1. Responsibility for Marking and Sealing	7
	5.2. Pre-Race Component Marking and Sealing	7
	5.3. Parc Fermé Component Marking	8
6.	POST-RACE TECHNICAL INSPECTION	8
7.	WHEN A RACE IS DECLARED WET	9
8.	GENERAL KART SPECIFICATIONS	10
	8.1. Eligible Chassis	10
	8.2. Main Frame Construction	10
	8.3. Roll Cages	10
	8.4. Overall Measurements	10
	8.5. Chassis Suspension	11
	8.6. Driver Position	11
	8.7. Floor Pans (Floor Tray)	11
	8.8. Steering Linkage Mechanisms	11
	8.9. Steering Shafts	11
	8.10. Steering Wheels and Hubs	11
	8.11. Brake Systems	12
	8.12. Front Wheel Retention	13
	8.13. Rear Axles	13
	8.14. Wheel Hubs	13
	8.15. Wheels	13
	8.16. Driver's Seat	14
	8.17. Composite Materials	14
	8.18. Front and Side Bumpers	14
9.	Front Fairing Push Back with CIK-FIA Front Fairing	19
10.	Rear Wheel Protection.....	19
	10.1. Plastic Rear Wheel Protection	19
11.	Rear Wheel Protection with Wheel Covers.....	20
12.	BODYWORK SPECIFICATIONS	21
	12.1. Components - Materials and Usage	21
	12.2. CIK Bodywork Specifications	21
	12.3. Bodywork Regulations	21
	12.4. Bodywork Specification	22
13.	Ballast Weight Mounting	28
14.	Fuel Tank and System	28
15.	Clutches	28
16.	Chain/Oil Guard.....	28
	16.1. Chain Oilers	29
	16.2. Changing Ratios	29

17.	Competition Numbers and Number Panels	29
18.	Instrumentation and Communication	29
19.	Throttle Return Spring	29
20.	Seat Belts and Mirrors	30
21.	Hand Controls	30
22.	Transponder	30
23.	Transponder Mounting Location	30
24.	Driver's Name	30
25.	Starter Batteries	30
26.	Airflow Control on Radiators	31
27.	TIRES	31
	27.1. Tire Specifications.....	31
	27.2. Tires for Use in Dry Track Conditions	31
	27.3. Tires for Use in Wet Track Conditions	31
28.	LOOSE OR LOST COMPONENTS	31
29.	CIK-FIA including KZ, KZ2, OK, OK-N, OK-Junior, Mini, Superkart, E-Karting	32
30.	Rok including Rok Micro, Mini, GP, VLR, Shifter	32
31.	Rotax including Senior Max, Junior Max, DD2, DD2 Masters, Mini Max, Micro Max	32
32.	Briggs & Stratton	32
33.	ALL OTHER CLASSES	32
34.	FUEL AND OIL REQUIREMENTS	32
35.	TWO CYCLE FUEL AND OIL REQUIREMENTS	32
	35.1. Source and Communication.....	32
	35.2. Lubricant Oils	32
36.	FOUR-CYCLE FUEL REQUIREMENTS - GASOLINE TO BE USED	33
37.	FUEL AND OIL TESTING	33
	37.1. General Conditions	33
	37.2. Fuel Checking Procedure	33
	37.3. Flame Test Procedure for Four Cycle Oil	33
38.	USE OF CAMERAS ON KARTS	34

1. THESE TECHNICAL REGULATIONS

The Spirit and Intent will be the standard by which these Regulations are enforced.

Covered, stated, restated, or unstated any change or action with the sole intent to wrongfully create a performance advantage is grounds for disqualification.

Compliance with ASN Technical Regulations does not necessarily ensure eligibility of karts by other sanctioning bodies.

Should doubt exist in the mind of a competitor, manufacturer, distributor, or Official as to the interpretation or application of these Regulations, the competitor, manufacturer, distributor, or Official is encouraged to first communicate in writing or email to the ASN or karting organization having jurisdiction. Verbal inquiries will not be considered.

In determining questions of eligibility of a kart, or the presence, absence, or condition of a component of a kart, Officials shall be guided by the principle:

“IF THE REGULATIONS DO NOT STATE THAT YOU CAN DO IT, YOU CAN NOT”

It is the entrant and/or driver's responsibility at all times to ensure the ongoing compliance with mechanical safety and chassis, bodywork and engine technical eligibility of the kart. A claim of lack of knowledge in the event of a kart being found ineligible, will not be considered.

Out of compliance parts, equipment or configuration on the kart, are not deemed to have been authorized or approved by reason of having passed through the inspection process at any time or any number of times.

ASN affiliated Regions and Clubs may adopt these Technical Regulations for use within their own organization. Regions and Clubs are encouraged to appoint a Technical Inspector and Assistants.

2. PARTS, COMPONENTS, MEASUREMENTS

All replacement parts are subject to these Regulations. Any part, hole, shape, dimension, measurement, or appearance not listed in these Regulations does not exclude it from inspection.

Production changes by the manufacturer of an engine, kart or part for a kart, or manufacturer of an aftermarket part causing any part not to conform to the specifications, or not to conform with the Spirit and Intent of these Regulations are subject to a decision ASN or by the karting organization having jurisdiction, as to whether or not the part will be considered eligible and permitted for use in competition.

A Technical Inspector may use additional means of measuring components to compare against a known compliant or stock part.

Manufacturer's manuals are part of the equipment specifications and may be used to reference eligibility of components.

Systems for the measuring of the maximum engine revs and/or the control of the clutch functioning may be used in categories where engine speed limits and/or limits regarding clutch functioning are prescribed. They shall be installed in the strict respect of the relevant instructions.

On the decisions of the Steward(s), the Technical Inspector will be authorized to interchange an Entrant's ignition system for the system supplied by ASN or the event organizer. The substitute ignition system to be of the same make and model as the one used by the Entrant concerned.

3. EQUIPMENT ENTRY REGULATIONS

3.1. Definition of a Kart

A kart is a land single seater vehicle without a roof or a cockpit, without suspension and with or without bodywork elements, with 4 nonaligned wheels that are in contact with the ground, the 2 front ones of which control the direction and the other 2 rear ones, connected by a one-piece axle, transmit the power. The main parts are the chassis (including the bodywork), the tires and the engine. The driving position is in the seat, with feet to the front.

3.2. Briggs & Stratton, Rok and Rotax have their own technical specifications.

The number of engines and chassis permitted will be in accordance with the Canadian Rotax Max Challenge Regulations and must be noted by serial number(s) and seal numbers(s) on the Rotax Engine "Identity Card" and Technical Self-Declaration form.

One engine of the same manufacturer and one chassis are permitted for each entry and must be noted by serial number(s) on the Technical Self-Declaration form unless stated otherwise in the supplementary regulations.

Changing to a second chassis may occur only if there is physical damage (to be considered un-repairable or broken) upon approval by the Technical Inspector. Changing to a second engine may occur only if there is physical damage upon approval by the Technical Inspector.

3.3. Repairs or Replacement After Technical Marking

- a) Repairs requiring the breaking of a seal or loss of a mark or changing of a chassis must be accomplished under the scrutiny of a Technical Inspector. The appropriate parts must re-sealed or re-marked and the entrant must start at the rear of the grid.
- b) **Rotax Classes:** Repair and/or replacement must be in accordance with Canadian Rotax Max Challenge Regulations.
- c) **All Other Classes:** Changing to a second engine may occur only if there is physical damage upon approval by the Technical Inspector. The engine must be sealed with paint and/or wire before competition use. The serial number of the second engine must be added to the Technical Inspection Self-Declaration sheet. The driver will start the next race from the rear of the grid.

Cleaning of carburetors is permitted in Four-Cycle classes. The cleaning must be approved by, and accomplished under, the scrutiny of a Technical Inspector. The appropriate parts must be re-marked with the entrant retaining their position on the starting grid.

A valve cover gasket that has oil leakage or a valve cover that is damaged in a manner that could cause oil leakage may be replaced. The replacement must be approved by and accomplished under the scrutiny of a Technical Inspector. The valve cover must be re-marked with the entrant retaining their position on the starting grid.

d) Kinked, Cracked, Loose or Broken Headers

At any time during the event the entrant will NOT lose their starting position for the next session or the Final Race when any of the following procedures are accomplished under the scrutiny of the Technical Official, and the exhaust header retainer is re-sealed:

Replacement of a broken, kinked, or cracked header. Re-tightening of the header retainer nuts.

Replacement of a stripped exhaust header stud or bolt. Repair of the exhaust threads in the head.

A cracked header must still be in a condition that will pass all post-race Technical Inspection. If not, the entrant is Disqualified.

A broken header will pass post-race Technical Inspection provided that the entire header/silencer is still attached to the kart by the support brace and/or the tether, AND the entire exhaust system is in compliance with the regulation. If the header and silencer are separated and cannot be presented to Technical Inspection as a complete unit, the entrant is Disqualified.

3.4. Exchanging of Equipment

There shall be no exchanging of tire(s), engine(s), or chassis between entrants. If an entrant is competing in more than one class, there shall be no exchanging of tires between classes. Drivers may only use equipment listed on their Technical Inspection Self-Declaration.

In all classes, if physical damage occurs to the engine(s) listed on the Pre-Technical Inspection Self-Declaration form or if a chassis has physical damage (non-repairable) that would prevent an entrant from competing, an unlisted replacement engine or replacement chassis may be used with the approval

of the Technical Inspector prior to use. The change must be noted on the Technical Self-Declaration form. In Rotax classes, a Rotax "Identity Card" must be submitted for the replacement engine. The appropriate parts must re-sealed or re-marked. An entrant using a replacement engine or chassis must start at the rear of the grid.

The penalties for unauthorized use of equipment include the following. If the infraction occurs in Qualifying, the driver to start at the rear of the first race. In Heat and Pre-Final races, a driver to be scored in last place and/or start at the rear in the next race. In Final races, the penalty is Disqualification.

4. PRE-RACE TECHNICAL INSPECTION

4.1. Technical Inspection Self-Declaration

Each participant must submit a fully completed Technical Self-Declaration form to the Technical Inspectors. Upon receipt of the completed Technical Self-Declaration form the competitor will be issued a Technical Inspection sticker.

Any changes required on the completed and submitted Technical Self-Declaration form must be completed and accepted by the Technical Inspectors before qualifying sessions begin in any class or before a designated time.

It is the competitor's responsibility to ensure that their kart meets the technical requirements for the class through the entire race event. Drivers found on the track without having completed and submitted a Pre-Technical Inspection Self-Declaration form are subject to penalty. Drivers who enter Post-Race Technical Inspection and are found to have not completed or submitted a Technical Self-Declaration form will be Disqualified.

Any Kart, safety equipment or apparel is subject to Technical Inspection at any time.

The Technical Self-Declaration form is retained by the Technical Inspector.

4.2. Technical Inspection Sticker

The event organizer shall provide a unique Technical Inspection sticker for each event. The sticker shall be water resistant and have a space large enough for the competitors two or three- digit kart number. The participant must attach the sticker to the designated location on the appropriate kart before it is allowed to enter the track for any session.



5. TECHNICAL MARKING PROTOCOL

5.1. Responsibility for Marking and Sealing

It is the responsibility of the driver to ensure that their entry has been properly marked or sealed for competition and Technical Inspection (engine, tires, and chassis where required) at any time during the competitive portion of the event. Failure to do so may cause penalty, as determined by the Steward(s) or Race Director.

5.2. Pre-Race Component Marking and Sealing

- a) The engine, tires and chassis used by a driver in qualifying will be marked, sealed or scanned by a Technical Inspector at a designated time and place before, during, or after the qualifying session before the driver and/or mechanic/tuner or Kart leaves the weigh-in area after qualifying.
- b) Dependent upon class, all engine and chassis markings must either form a seal from one part to another or be an identifying mark.
- c) All tires must have been marked on the inner sidewall in a manner determined by a Technical Inspector or scanned at some time before leaving the weigh-in area after qualifying.
- d) Latex paint is recommended for engine marking.

5.3. Parc Fermé Component Marking

When a Parc Fermé is used, all tires, fuel tanks, and fuel supply reservoirs shall be marked with the competition number of the entrant, at a determined time, before qualifying.

6. POST-RACE TECHNICAL INSPECTION

- a) At the conclusion of any track session, the Steward(s) and/or the Technical Inspector may select karts for inspection, and the competitors involved shall without delay take the selected karts directly to the Parc Fermé/Technical Impound/Inspection area.
- b) At the conclusion of a race all karts are deemed to be impounded and must remain in the exact condition in which they left the racetrack until released by the Steward(s) and/or Technical Inspector or designate.
- c) It is incumbent on the entrant/driver to determine whether or not their kart has been selected for inspection by reporting immediately to the Parc Fermé/Technical Impound/Inspection area for inspection or release by the Technical Inspector or designate.
- d) Failure to present the kart promptly at the Parc Fermé/Technical Impound/Inspection area when requested may result in a penalty. Penalties include, a fine, being scored in last place and/or starting at the rear of the grid for the first/next race or Disqualification. Any such penalty is not subject to protest or appeal.
- e) One entrant/driver and/or one mechanic/tuner must attend each kart at the Parc Fermé/Technical Impound Inspection Area. Technical inspection may begin on a kart or engine without the entrant/driver and/or mechanic/tuner being present.
- f) In addition to the vehicle and its components, anything mounted on or in a kart may be impounded by the Steward(s) or Technical Inspector.
- g) The entrant/driver is responsible for all costs, if any, associated with the teardown, inspection and rebuilding of any component(s) selected for eligibility verification by the Steward(s)
- h) A qualifying position or a race finishing position, and any Club or Series points and other awards available to a competitor that is subjected to an eligibility verification, may be withheld until the results of any inspection are determined.
- i) The entrant/driver is responsible for ensuring that the kart is returned to proper operating condition after any impound or inspection by the Technical Inspector or support personnel. Protests will not be allowed in this regard.
- j) Technical inspection begins when the inspector checks the technical engine markings and the tire markings. If any seals are broken or missing, or tires or chassis unmarked, then the entrant/driver will receive a penalty. Penalties include being scored in last place and/or starting at the rear of the grid for the first/next race or Disqualification. The engine or other components may still be inspected as determined by the Technical Inspector. If the seals are unbroken and present a detailed engine inspection should begin to a level determined by the Technical Inspector.
- k) If, at any point during the inspection, an engine or other components are found to be in contravention of these Regulations, the inspection may proceed at the discretion of the Technical Inspector. The Technical Inspector will notify the Steward(s) of the technical infraction by the entrant/driver. If the entrant/driver does not submit an approved complete Refusal of Appeal form, the part(s) in question can be retained by the Technical Inspector. If the entrant wants the part(s) in question to be returned it is the responsibility of the entrant to obtain the approved Refusal of Appeal form and submit the completed form to the Chief Steward. If the part(s) in question are removed from the impound area by the entrant/driver or mechanic/tuner without permission from the Technical Inspector, or Steward(s), or without a Refusal of Appeal form being submitted the entrant/driver will be Disqualified from the results and no protest or appeal can be submitted.

The Technical Inspector shall label the impounded racing equipment and one of these officials will be responsible for providing the impounded racing equipment at an appeal hearing if called.

- l) The Technical Inspector may use any tool(s) required for the inspection. If an engine manufacturer specifies that specific tools must be used (example Briggs & Stratton) the Technical Inspector must use these tools.
- m) If a technical infraction is found, the findings of the Technical Inspector must be immediately communicated to the Steward(s). The Steward(s) will determine if a penalty will be applied, and the severity of the penalty based on the circumstances of the violation. Refer to the ASN Standard Karting Penalties chart for penalty guidelines.
- n) Post-Race Technical Infractions can be either Pre-Race Technical Inspection or Equipment related. The penalties for deviations from the Technical Self-Declaration or Rotax Engine "Identity Card" include monetary fines, position penalties or Disqualification at the discretion of the Steward(s).

7. WHEN A RACE IS DECLARED WET

The choice of wet or dry tires will be decided by the individual driver.

All Technical Regulations will be adhered to, except as follows:

- a) If wet tires are to be used, they are defined as any production type tires that have been manufactured by any Kart tire manufacturer specifically for wet weather conditions.
- b) Specified manufacturers and compounds of tires may be required. A competitor may not mix and match tires from different manufacturers or different designations or compounds.
- c) Modified, grooved or otherwise altered dry condition tires are not acceptable.
- d) The rear wheels may be moved inward, to narrow track width to the limit permitted in the Technical Regulations for minimum width, but the axle ends may not protrude beyond a plane drawn across the outer face of the rear wheel.
- e) Rear protection or the rear bumper must have an overall width not exceeding the rear width of the kart at any time, measured outside the rear wheels or tires, whichever is the greater, during both DRY and WET conditions.
- f) A deflector may be added to the air filter on four-cycle engines provided that such additions do not provide a ram-air effect.
- g) Front and rear wet rims and tires must be used at the appropriate locations if wet tires are used.
- h) A rain deflector may be added to prevent water from entering the intake silencer. The deflector must be constructed of non-metallic material. In classes except Rok, the rain deflector can be securely attached to the chassis frame and/or metal side bumper bars. There can be no modifications or attachments whatsoever to the plastic side pods. In Rok classes the rain deflector must be secured to the airbox on the engine not to the chassis.

8. GENERAL KART SPECIFICATIONS

8.1. Eligible Chassis

- a) CIK-FIA homologated chassis must conform to Chassis Regulations as published in the CIK-FIA Karting Technical Regulations.
- b) In the Rotax Max Challenge classes, only chassis allowed by the Canadian Rotax Max Regulations are permitted.
- c) For all other classes, eligible chassis include those homologated/registered by the CIK-FIA and any chassis that in the opinion of ASN or the karting organization having jurisdiction reasonably meet the intent and technical requirements of these regulations. Decisions regarding technical eligibility and compliance in all classes are reserved for ASN or the karting organization having jurisdiction and the Technical Inspector.
- d) Decisions made on chassis eligibility are final and are not subject to protest or appeal.

8.2. Main Frame Construction

- a) In addition to compliance with the Spirit and Intent of the Rules, overall quality of workmanship is considered in the acceptance of a Kart presented for competition. Tubular steel construction is the only type of frame design method currently considered to be within the Spirit and Intent of the Rules of all classes.
- b) The frame must be made from magnetic structural steel or structural steel alloy.
- c) The centers of main frame rail tubes may be no higher than a line projected horizontally between the centers of the front and rear wheel hubs.
- d) Minimum tubing outer diameter: 1.000" (25.4 mm)
- e) Maximum tubing outer diameter: 1.400" (35.56 mm)
- f) Minimum tubing wall thickness for tubing 1.125" OD or less: 0.078" (1.98 mm)
- g) Minimum tubing wall thickness for tubing over 1.125" OD: 0.060" (1.53 mm)

8.3. Roll Cages

The addition of a roll cage to the kart chassis-frame is not permitted unless there is a class designation for roll cage equipped karts. Karts with roll cages are not permitted to run on a track at the same time as karts without roll cages.

8.4. Overall Measurements

Spec	Class	Min. Wheelbase (Note 1.)	Max. Wheelbase (Note 1.)	Min. Track Width	Max. Overall Width	Min. Kart Weight (Note 4.)
A.	TWO CYCLE Classes including: Junior, Senior, Masters	101 cm	110 cm	Note 2.	140 cm	59 kg (130 lbs)
B.	TWO CYCLE Classes including: Mini Rok, Rotax Micro MAX, Rotax Mini MAX	89 cm	95 cm	Note 3.	120 cm	59 kg (130 lbs)
C.	FOUR CYCLE Classes including: Junior, Senior, Masters	101 cm	110 cm	Note 2.	140 cm	59 kg (130 lbs)
D.	FOUR CYCLE Classes including: Junior, Senior, Masters	101 cm	110 cm	Note 3.	127 cm	59 kg (130 lbs)
E.	Cadet	89 cm	95 cm	Note 3.	120 cm	54 kg (119 lbs)

Spec C. or D. for FOUR CYCLE classes to be specified in the Supplementary Regulations.

Note 1. Wheelbase is measured between front and rear true axle centers.

Note 2. Minimum Track Width: A line passing through the outer edges of the front and rear tires (steering wheel in straight ahead position) must be a minimum of 4 cm wider than the appropriate side pod. Maximum width of rear wheel is 215 mm. (See 8.15. Wheels)

Note 3. Minimum Track Width: Each outer edge of the rear wheels may be a maximum of 2.5 cm narrower than the outer width of the appropriate side pod. Width of rear wheel is 175 mm MIN. - 185 mm MAX. when using DRY tires. (See 8.15. Wheels)

Note 4. Minimum Kart Weight is less driver, fully equipped and race ready.

Maximum Overall Length: Measured without front and/or rear fairing. All classes 182 cm.

Maximum Overall Height: Measured from the ground to the uppermost part of the Kart, less driver, fully equipped and race ready. All classes 65 cm.

8.5. Chassis Suspension

The use of or attempt to create and/or conceal any suspension movement is prohibited. Normally, this includes springs, shocks, spring washers, grommets, etc. Torsion bars are not considered suspension.

8.6. Driver Position

When normally positioned on the Kart for racing competition, the entire driver shall be within the specified width and length dimensions of the Kart.

8.7. Floor Pans (Floor Tray)

It is mandatory to have a floor tray made of rigid material stretching from the central strut to the front of the chassis frame.

The floor tray must fit completely within the perimeter formed by the main tubes, i.e. the central strut, the longitudinal tubes and the front of the chassis frame, without protruding beyond the central axis of the tubes seen from the top. It must be made of a single element, and its surfaces must be uniform, solid, rigid, impenetrable, smooth, without ribs and of constant thickness.

It must be laterally edged by a tube or a rim preventing the driver's feet from sliding off the floor tray.

The floor tray may be perforated, but the holes must not have a diameter of more than 10 mm and they must be separated by four times their diameter as a minimum. In addition, two holes with a maximum diameter of 35 mm are allowed for steering column and/or gear shift lever access.

The floor tray may be made of composite material.

8.8. Steering Linkage Mechanisms

All steering linkage must be of the direct, mechanical type.

All steering assembly fasteners must be either cotter-pinned, safety wired, secured by snap rings, or utilize self-locking nuts in original condition.

All bolts shall be at least Grade 5 or US Mark 3 of a minimum of 6 mm diameter. All rod ends must be universal type swivel joints.

8.9. Steering Shafts

Tiller/vertical shaft steering mechanisms are not allowed.

Steering shafts must be 18 mm minimum OD steel tubing of one-piece design, 1.8 mm minimum wall thickness, with a minimum 5/16" (8 mm) diameter fastener at the base.

Dynamic Kart Steering (DKS) kits which may include a replacement steering column bushing and attachments to the steering shaft and tie rods that allows changes to toe in and toe out settings while a kart is in motion are not allowed.

8.10. Steering Wheels and Hubs

Steering must be controlled by a steering wheel which a continuous rim not incorporating any reflex

angles in its basic shape. The upper and lower 1/3 of the circumference may be straight or of a different radius to the rest of the wheel. The rim must be manufactured with a metallic structure made of steel or aluminum.

The one-piece steering hub will be secured with a minimum 6mm diameter Grade 5 or US Mark 3, or 6 mm bolt and nut, perpendicular to the longitudinal centerline of the shaft.

It is recommended that the unthreaded portion of this bolt be long enough to clear both the shaft and the hub utilizing a washer(s), if necessary, to enable proper tightening.

Welding of the steering wheel to the hub is NOT allowed. Welding the steering wheel hub to the shaft is NOT allowed.

No shaft extensions are allowed.

Minimum steering wheel outer diameter is 25.4 cm.

The steering wheel must have a minimum of three spokes.

The steering wheel must be of closed loop design and circular, except that the upper or lower 1/3 of the wheel circumference may be flat.

Any device mounted on the steering wheel must not protrude by more than 20 mm from the plane forward of the steering wheel and must not have sharp edges. Flexible steering controls by cable or chain are forbidden. All parts of the steering must have a method of attachment offering maximum safety (split pins, self-locking nuts, or burred bolts). The steering column must have a minimum diameter of 18 mm and a minimum wall thickness of 1.8 mm.



8.11. Brake Systems

All Karts, at a minimum, must be equipped with a braking system that brakes the rear wheels.

Except for disc retention, fasteners related to the braking system must be secured with one of the following methods:

- Single nut with cotter pin or safety wire
- Double nuts
- Snap rings
- Self-locking nuts – metallic or plastic type

Each fastener used for rear brake disc retention must be secured either by cotter pin, or safety wire, or snap ring(s), or utilize completely metallic locking nuts.

“Floating” front disc brake retention shall be as manufactured, or by self-locking nuts (metallic or plastic type), or by nuts that are cotter pinned, safety wired or utilize snap rings.

Brake rotors shall have no cracks or major chips.

Brake pads must be of sufficient area and thickness for proper braking for the duration of the event.

Brake discs must be made from steel, stainless steel or cast iron. Carbon and ceramic brake discs are forbidden.

8.12. Front Wheel Retention

Chassis that are CIK-FIA homologated/registered or meet CIK-FIA requirements can have a self-locking style retention nut in original condition. All front axle spindles that are manufactured to receive a cotter pin, safety wire or snap ring must have these items installed.

8.13. Rear Axles

Rear axles must be of one-piece design.

For 40 mm diameter rear axles in all four-cycle classes, minimum cross-sectional tube thickness is 2.40 mm.

Axles must be constructed from a magnetic iron or steel-based material. For example, aluminum, stainless steel, titanium, and carbon fiber axles are NOT allowed.

The following table lists the minimum cross-sectional tube thickness at any point in a rear axle, except for key housings, or snap ring grooves at the outer extremities for all classes unless otherwise noted.

Rear Axle thickness according to outer diameter			
Maximum external diameter (mm)	Minimum thickness (mm)	Maximum external diameter (mm)	Minimum thickness (mm)
50	1.9	37	3.4
49	2.0	36	3.6
48	2.0	35	3.8
47	2.1	34	4.0
46	2.2	33	4.2
45	2.3	32	4.4
44	2.4	31	4.7
43	2.5	30	4.9
42	2.6	29	5.2
41	2.8	Less than 28	Full
40	2.9		
39	3.1		
38	3.2		

8.14. Wheel Hubs

Wheel hubs must be constructed of metallic materials. Both rear hubs must be keyed properly to the rear axle.

8.15. Wheels

Wheel: defined as the assembly of a rim with a pneumatic tire, for the driving and/or propulsion of the kart.

Wheel Width: defined as the distance between the inner and outer extremities of the wheel.

Maximum beading diameter is 5.0" (127 mm)

Maximum width of any front wheel is 135 mm.

In Rotax classes using MOJO tires, the maximum front rim width is 135 mm

Width of any rear rim in all Junior and Senior four-cycle classes is 175 mm MIN. - 185 mm MAX. when using DRY tires

Width regulations for Novice, Cadet, **Micro and Mini classes front and rear rims 130 mm +/- 5 mm.**

Regulations Maximum width of rear wheel in all other classes is 215 mm

The use of automatic pressure regulating valves is prohibited.

8.16. Driver's Seat

Only bucket type seats are permitted. Seat must be of one-piece molded construction, with no add-on sections. Seat must be in good condition.

The seat must securely locate the driver laterally and longitudinally.

The seat must be bolted securely and rigidly in at least four places to the frame without using any damping devices and must not be adjustable while the kart is moving.

No portion of the seat may be located rearward of a plane projected vertically from the back of the rear axle.

Seat height requirements (top of seat) are as follows, measured from the ground:

Cadet/Novice: 10.0" (25 cm) minimum

Junior classes: 12.0" (30 cm) minimum

All others: 14.0" (35 cm) minimum

Shape and size of seats may be modified providing that the complete pattern area of all four final mounting locations are all located in the unaltered portion of the seat.

8.17. Composite Materials

Material composed of several distinct components that, when combined, provide properties that none of the individual components possess. As per CIK-FIA regulations, chassis skid plates, floor trays, seats, radiator air baffles and chain guards can be made of composite material. Only carbon fiber, glass fiber and kelvar are allowed.

8.18. Front and Side Bumpers

Front and side bumpers are compulsory. All bumpers must be made of magnetic steel. All bumpers must remain as originally manufactured.

All CIK-FIA Homologated chassis must conform to their appropriate CIK-FIA Homologations for front and side bumpers. The front, rear and side bumpers must be homologated with the corresponding bodywork.

All non-CIK-FIA homologated chassis must have bumpers that conform to with either a) or to the CIK-FIA homologated bumper regulations described in b). Due to their non-CIK-FIA status and/or age, some deviations may be allowed by the Technical Director that do not affect safety.

a) Front Bumpers:

The minimum outer diameter of the tubing is 15 mm (0.590").

All front bumpers must be, at some point in the horizontal section of any of the frontal contact portion of the bumper, present when measured at 15 cm to 22 cm from the ground, as raced.

The front bumper must be mounted vertically above the chassis front member and attached to it in up to four places.

There shall be front and lateral protection. The bumper must not project beyond a line drawn through the outside of the front and rear wheels at hub height, with the front wheels in the straight-ahead position.

b) Side Bumpers Paired with Wheel Covers

Side bumpers paired with wheel covers are optional for all classes.

The side bumper paired with wheel covers consist of two elements of magnetic steel round tubing that are centered in relation to the longitudinal axis of the kart. Each element must be composed of a lower and an upper bar. They must have a diameter of 20.0 mm.

The minimum straight length is 400.0 mm for the lower bar and 300.0 mm for the upper bar. Overall width: 480.0 mm minimum and 580.0 mm maximum for the lower bar, 480.0 mm minimum and 660.0 mm maximum for the upper bar (measured to the tube midpoint) in relation to the longitudinal axis of the kart. Each bar must be fixed to two welded tube attachments that must be 500.0 ± 5 mm apart (measured to the tube midpoint). These attachments must be parallel to the ground, perpendicular to the axis of the chassis and allow for a 50.0 mm insertion of the bar.

Height of the upper bar: 160.0 mm minimum from the ground (measured to the tube top). See Technical Drawings No. 2.0a, No. 2.1b and 3.1b.

c) Side Bumper Bars for Non-CIK-FIA Homologated Chassis:

Side bumper bars must be constructed of minimum 18 mm diameter steel tubing, must be secured by minimum 6 mm diameter bolts, and must allow for secure mounting of side pods.

The overall length of the side bumper bar shall be a minimum of 400 mm, measured from the backside of the side bumper bar closest to the rear tire, in a straight line to where it attaches to the kart at the front.

The rear portion of the side bumper bar may not protrude laterally beyond the rear tire, unless otherwise noted.

d) Bumpers for CIK-FIA Homologated Chassis:

CIK-FIA Homologated karts must maintain their homologated bumper specifications.

Specification for all Classes Except Mini

DESSIN TECHNIQUE N°2.0

Pare-chocs pour circuits courts - Groupes 1 & 2

T4: Upper tube ϕ 20
with a straight length: /
Tube supérieur ϕ 20
avec une partie droite:
300 min.

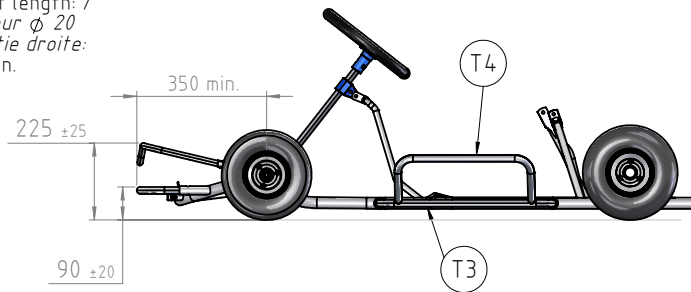

T3: Lower tube ϕ 20
with a straight length: /
Tube inférieur ϕ 20
avec une partie droite:
400 min.

M2: Horizontal attachments
perpendicular to axis A /
Fixations horizontales et
perpendiculaires à l'axe A

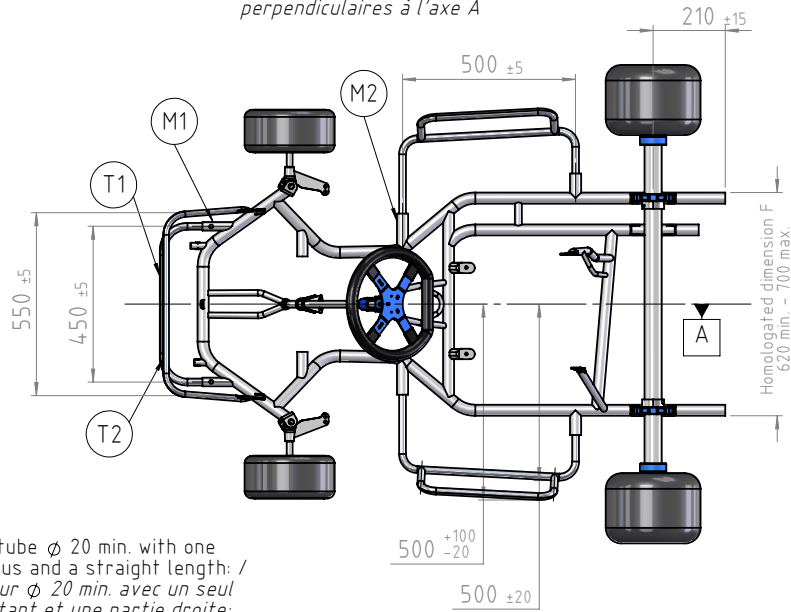

T1: Lower tube ϕ 20 min. with one
constant radius and a straight length: /
Tube inférieur ϕ 20 min. avec un seul
rayon constant et une partie droite:
295 min. - 315 max.

T2: Upper tube ϕ 16 min. with one
constant radius and a straight length: /
Tube supérieur ϕ 16 min. avec un seul
rayon constant et une partie droite:
375 min. - 395 max.

M1: Lower attachments
horizontal and parallel to axis A
Fixations inférieures horizontales
et parallèles à l'axe A

Cotes en/Dimensions in mm

DESSIN TECHNIQUE N°2.0a

TECHNICAL DRAWING No 2.0a

Front bumpers for short circuits – Groups 1 & 2

Side bumpers paired with wheel covers

T4: Upper tube ϕ 20
with a straight length: /
Tube supérieur ϕ 20
avec une partie droite:
300 min.

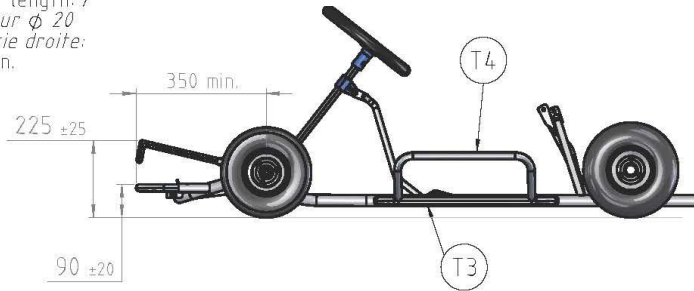

T3: Lower tube ϕ 20
with a straight length: /
Tube inférieur ϕ 20
avec une partie droite:
400 min.

M2 : Horizontal attachments
perpendicular to axis A /
Fixations horizontales et
perpendiculaires à l'axe A

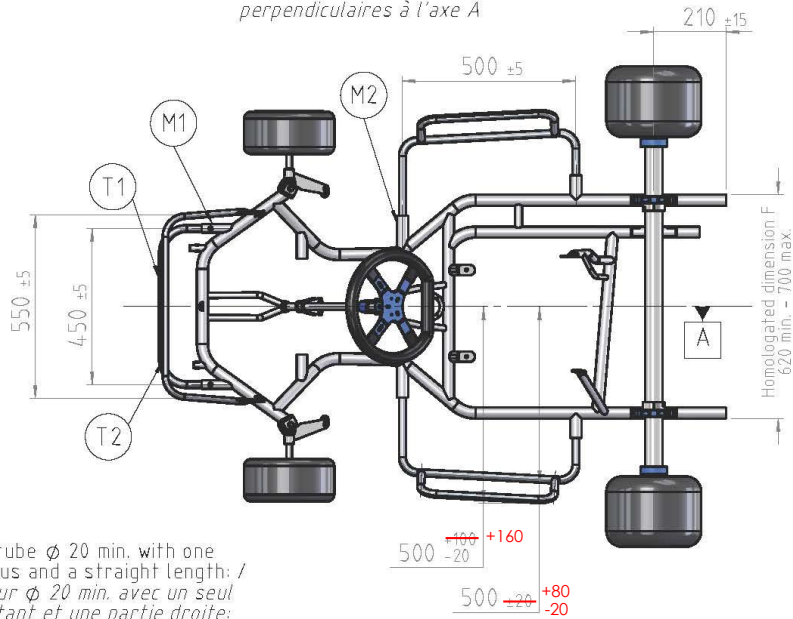

T1: Lower tube ϕ 20 min. with one
constant radius and a straight length: /
Tube inférieur ϕ 20 min. avec un seul
rayon constant et une partie droite:
295 min. - 315 max.

T2: Upper tube ϕ 16 min. with one
constant radius and a straight length: /
Tube supérieur ϕ 16 min. avec un seul
rayon constant et une partie droite:
375 min. - 395 max.

M1: Lower attachments
horizontal and parallel to axis A
Fixations inférieures horizontales
et parallèles à l'axe A

Cotes en/Dimensions in mm

Specification for Mini

DESSIN TECHNIQUE N°3.0a

TECHNICAL DRAWING No. 3.0a

Pare-chocs - Groupe 3

Bumpers - Group 3

T4: Upper tube ϕ 20
with a straight length: /
Tube supérieur ϕ 20
avec une partie droite:
180 min.

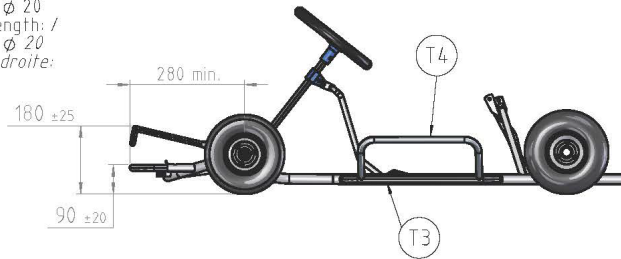

T3: Lower tube ϕ 20
with a straight length: /
Tube inférieur ϕ 20
avec une partie droite:
280 min.

M2: Horizontal attachments
perpendicular to axis A /
Fixations horizontales et
perpendiculaires à l'axe A

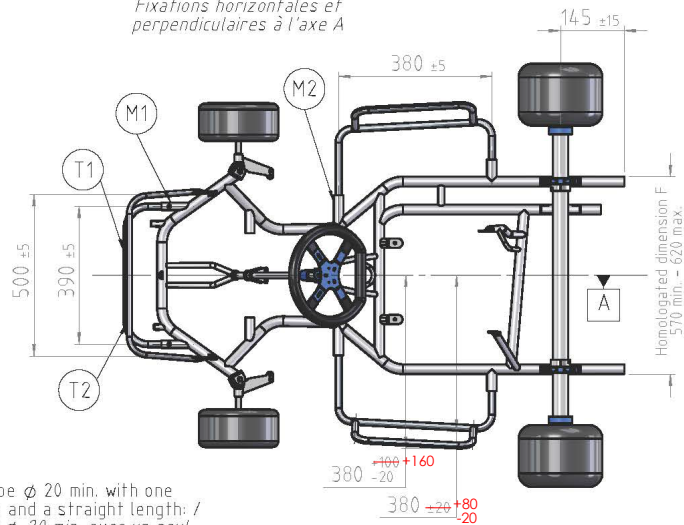

T1: Lower tube ϕ 20 min. with one
constant radius and a straight length: /
Tube inférieur ϕ 20 min. avec un seul
rayon constant et une partie droite:
270 min.

T2: Upper tube ϕ 16 min. with one
constant radius and a straight length: /
Tube supérieur ϕ 16 min. avec un seul
rayon constant et une partie droite:
300 min.

M1: Lower attachments
horizontal and parallel to axis A
Fixations inférieures horizontales
et parallèles à l'axe A

Cotes en/Dimensions in mm

370

Cotes en/Dimensions in mm

9. Front Fairing Push Back with CIK-FIA Front Fairing

The use of a CIK-FIA homologated front fairing and homologated front fairing mounting kit is mandatory.

The kit sits between the front bumper bars and the front fairing.

When subjected to contact which exceeds the load limit, the mounting bracket and front fairing move rearwards to then sit slightly 'loose' between the front bumper bars.

The front fairing must be in the correct position and meet technical requirements at all times. Parts with wear and tear must be rectified or replaced. Any **additions or any** form of reinforcement such as clamps, nuts/bolts, tie wraps, tape, wire, etc., is not allowed.

Touching the front fairing is not permitted after taking grid position until passing post-race technical inspection unless authorized by an Official.

Violations and Penalties:

The Black Flag with Orange Disc will not be shown to a Driver if the front fairing is no longer in the correct position. Officials will determine if the front fairing is no longer in the correct position after a qualifying session or race is completed.

Violation: Touching front fairing during any track session, in scale and/or Technical Inspection area prior to being released by officials. Penalty: Disqualification, 5 Penalty Points.

Violation: Front fairing not in correct position, one side pushed back. Penalty: 5 second time penalty, 5 Penalty Points.

Violation: Front fairing not in correct position, both sides pushed back. Penalty: 5 second time penalty, 5 Penalty Points.

The following regulation can be used if specified in the Supplementary Regulations:

Violation: If one side of the front fairing is pushed back a warning will be issued that is recorded. If the driver has a second one side push back during the same race event, a 5 second time penalty and 5 Penalty Points will be issued.

Officials may not vary the violation and penalties. Front fairing penalties are not subject to protest or appeal. It is recommended that Officials take a photo of each violation.

The document ASN-CDN-Front-Fairing-Push-Back.pdf with CIK Technical Drawings is available at <https://www.asncanada.ca>

10. Rear Wheel Protection

Rear protection is compulsory for all classes.

When the chassis used is a CIK-FIA homologated chassis that incorporates full-width plastic rear protection in the homologation, the homologated rear protection must be used as homologated.

Rear protection to have an overall width not exceeding the rear width of the kart at any time, measured outside the rear wheels or tires, whichever is the greater.

Rear protection to cover at least 50% of each wheel/tire assembly at all times measured at the center-line of the tire.

The construction of the rear protection must not present any danger as regards safety.

All Rotax classes requiring rear protection must conform to Rotax Max Challenge Regulations.

10.1. Plastic Rear Wheel Protection

Chassis fitted with a full-width plastic rear protection must conform to the following specifications:

The rear wheel protection must be made by injection blow molding, without foam filling, and must not present any risk with regard to safety.

Under no circumstance may it be located above the plane defined by the top of the rear wheels.

The surface of the rear wheel protection must be uniform and smooth; the rear wheel protection must not comprise cuttings or openings other than those homologated.

The rear wheel protection must be fastened to the homologated chassis by at least two points using supports homologated with the protection. These supports must be mounted (possibly by means of a flexible system) on the two main tubes of the chassis (respecting the homologated dimension F).

Only the chassis manufacturer is allowed to modify the chassis to mount the rear wheel protection.

Rear wheel protection must be placed at the height of the rear wheels.

Gap between the front of the rear protection and the surface of the rear wheels: 15 mm minimum and 50 mm maximum.

Width: 1,040 mm minimum, maximum that of the overall rear width.

Ground clearance: 25 mm minimum and 60 mm maximum in at least three spaces of a 180 mm minimum width, located in the extension of the rear wheels and the centreline of the chassis.

Adjustable plastic rear protection is allowed in all classes.

Non-homologated chassis may be retrofitted with full-width plastic rear protection that is used on a CIK-FIA homologated chassis provided the original mounting points to the chassis are used and the minimum and maximum dimensions are followed.

11. Rear Wheel Protection with Wheel Covers

Rear wheel protection with wheel covers is optional for all classes.

The rear wheel protection with wheel covers must consist out of three parts, one rear protection part and two rear wheel covers. The rear wheel covers must be made by injection moulding. The rear protection must be made by air blown moulding without foam filling and must not present any risk with regard to safety.

The wheel covers must be attached to the rear wheel protection.

The surface of the rear wheel protection with wheel covers must be uniform and smooth; it must not comprise cuttings or openings other than those homologated.

The rear wheel protection with wheel covers must be fastened to the homologated chassis at least two points using supports homologated with the protection. These supports must be mounted (possibly by means of a flexible system) on the two main tubes of the chassis (respecting the homologated dimension F).

This support, but not the rear wheel protection with wheel covers itself or the support it is mounted onto, can be secured with a cable or cable tied to the chassis.

Only the chassis manufacturer is allowed to modify the chassis in order to mount the rear wheel protection with wheel covers.

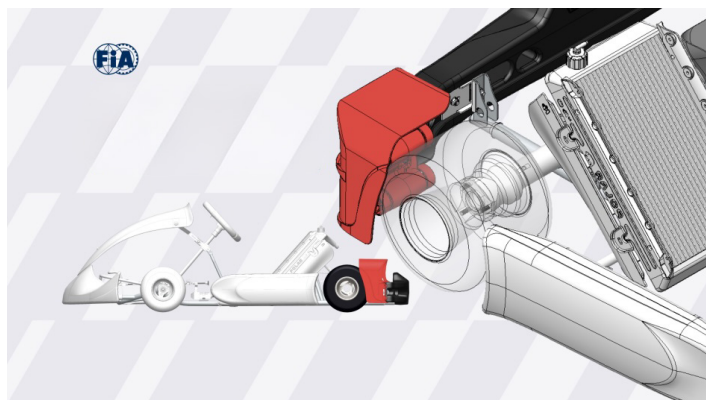

12. BODYWORK SPECIFICATIONS

12.1. Components - Materials and Usage

- a) Required bodywork components are: One front panel, one front fairing, two side pods, and associated mounting brackets and rear wheel protection as required in their Homologation.
- b) The combination of CIK-FIA Homologated bodywork (side pods, front fairing, front panel) of different makes or models is authorized. Both side pods must utilize their respective homologated side bumpers and must be used as a matched set. The front fairing must utilize its respective homologated front bumper.
- c) Front fairing and side pods must remain attached at their normal attachment points to the Kart after the completion of any session/race.
- d) Front fairing must be attached to the Kart with the appropriate Homologated apparatus. Any form of reinforcement such as clamps, nuts/bolts, tie wraps, tape, wire, etc., is not allowed.
- e) No element of the bodywork may be used as fuel tank or for the attachment of ballast.
- f) Plastic used for the bodywork must not be able to splinter, shall have no sharp angles and shall not be made of Plexiglas-type materials.
- g) No cutting of bodywork elements is allowed.
- h) No attachments to bodywork are allowed except for decals and allowed cameras and mounts.

12.2. CIK Bodywork Specifications

CIK-FIA Homologated chassis must have CIK-FIA Homologated bodywork as required for the particular chassis.

12.3. Bodywork Regulations

Side Pods:

The side pods must under no circumstances be located above the plane through the top of the front and rear tires (with the front wheels in the straight-ahead position).

In 2 cycle classes, side bodywork may not be located outside the plane drawn through the external part of the front and rear wheels (with the front wheels in the straight-ahead position).

In 4 cycle classes, side bodywork may be located outside the plane from the external part of the front to the rear wheels by a maximum of 2.5 cm.

They may not be located inside the vertical plane through the two external edges of the wheels (with the front wheels in the straight-ahead position) by more than 40 mm.

They must have a ground clearance of 25 mm minimum and of 60 mm maximum.

The surface of the side bodywork must be uniform and smooth; it must not comprise holes or cuttings other than those necessary for their attachment.

Gap between the front of the side bodyworks and the front wheels: 150 mm maximum. Gap between the back of the side bodyworks and the rear wheels: 60 mm maximum.

No part of the side bodywork may cover any part of the Driver seated in his normal driving position. The side bodyworks must not overlap the chassis-frame seen from underneath.

They must be solidly attached to the side bumpers.

On their outer rear vertical surface close to the rear wheels there must be a space for competition numbers.

Side Bodywork Paired with Wheel Covers:

The surface of the side bodywork paired with wheel covers must be uniform and smooth; it must not comprise holes other than those necessary for attachment purposes. No part of the side bodywork may cover any part of the driver seated in the normal driving position.

It must not overlap the chassis frame seen from underneath. It must not be able to retain water, gravel or any other substance and must be securely attached to the side bumpers. A space for racing numbers must be provided on the vertical surface close to the rear wheels. The side bodywork must under no circumstances be positioned above the plane defined by the tops of the front and rear tyres and must extend between 30.0 mm and 40.0 mm beyond the plane defined by the outside edge of the rear wheel, in accordance with technical drawing 2.1.b. The side bodywork must have a ground clearance of 25.0 mm minimum and 60.0 mm maximum. Gap between the front of the side bodywork and the front wheels: 150.0 mm maximum. Gap between the back of the side bodywork and the rear wheels: 60.0 mm maximum. In wet weather conditions, the side bodywork must protrude beyond the plane defined by the outer edge of the rear wheels by at least 30.0 mm, but not more than 40.0 mm. See Technical Drawings No. 2.0a, No. 2.1b and 3.1b.

Front Fairing:

Front fairing must remain attached at the normal attachment points to the Kart after the completion of any on track session or race.

Front fairing must be attached to the Kart with the appropriate homologated apparatus. Any form of reinforcement such as clamps, nuts/bolts, tie wraps, tape, wire, etc., is not allowed.

Front Panel:

It must not be located above the horizontal plane through the top of the steering wheel.

It must allow a gap of at least 50 mm between it and the steering wheel and it must not protrude beyond the front fairing.

It must neither impede the normal functioning of the pedals nor cover any part of the feet in the normal driving position.

Its width is 250 mm minimum and 300 mm maximum.

Its lower part must be solidly attached to the front part of the chassis-frame directly or indirectly. Its top part must be solidly attached to the steering column support with one or several independent bar(s).

A space for competition numbers must be provided.

All Bodywork:

Bodywork with cuts or worn through holes, excessive damage or wear must be replaced.

12.4. Bodywork Specification

CIK-FIA Homologated karts must maintain their homologated bodywork together with the accompanying bumpers and attachments. Combining homologated bodywork elements is allowed. However, the two side pods must be used together as a set.

Bodywork Specification for all Classes Except Mini

DESSIN TECHNIQUE N°2.1

Carrosserie pour circuits courts - Groupes 1 & 2

TECHNICAL DRAWING No. 2.1

Bodywork for short circuits - Groups 1 & 2

No bodywork above line B /
Pas de carrosserie au-dessus de la ligne B

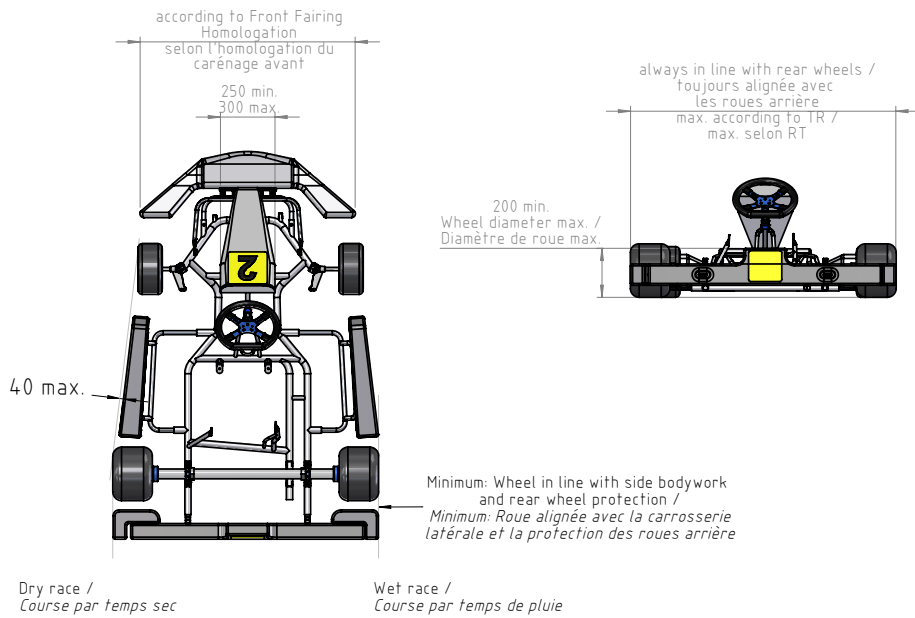
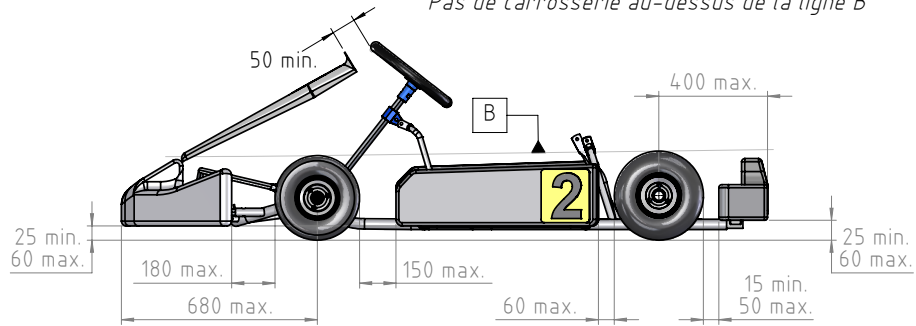

Cotes en/Dimensions in mm

DESSIN TECHNIQUE N°2.1a

TECHNICAL DRAWING No. 2.1a

Carrosserie pour circuits courts - Groupes 1 & 2

Bodywork for short circuits - Groups 1 & 2

No bodywork above line B /
Pas de carrosserie au-dessus de la ligne B

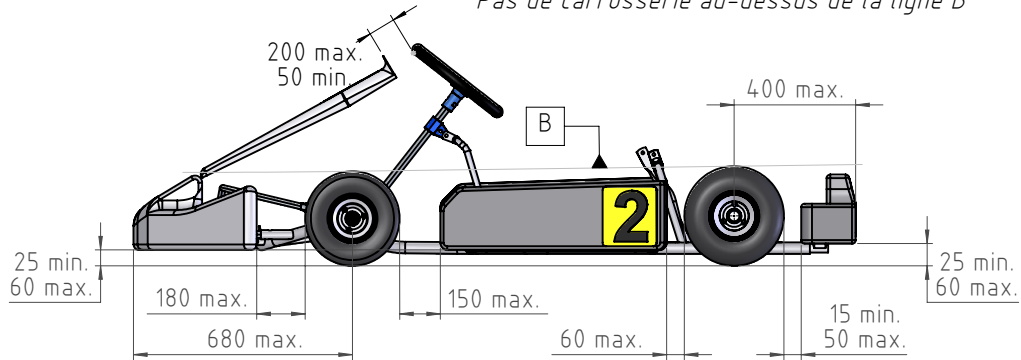

La distance maximale entre le bord supérieur central du panneau avant et le bord du volant en son point central ne doit pas dépasser 200 mm.
La mesure doit être effectuée avec le volant en position droite.

The maximum distance between the upper centerline of the front panel and the leading edge of the steering wheel at its center point must not exceed 200 mm.
The measurement is to be conducted with the steering wheel in a straight position.

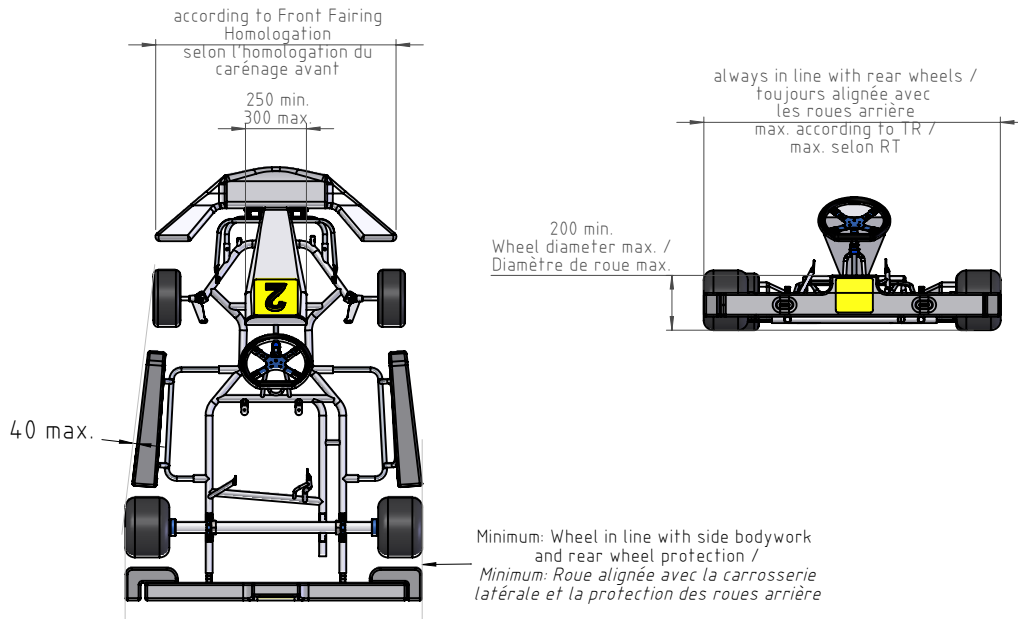

Dry race /
Course par temps sec

Wet race /
Course par temps de pluie

Cotes en/Dimensions in **mm**

DESSIN TECHNIQUE N°2.1b

TECHNICAL DRAWING No 2.1b

Bodywork for short circuits – Groups 1 & 2 and Rear Wheel Protection with wheel covers

Except rear wheel cover No bodywork above line B /
Pas de carrosserie au-dessus de la ligne B

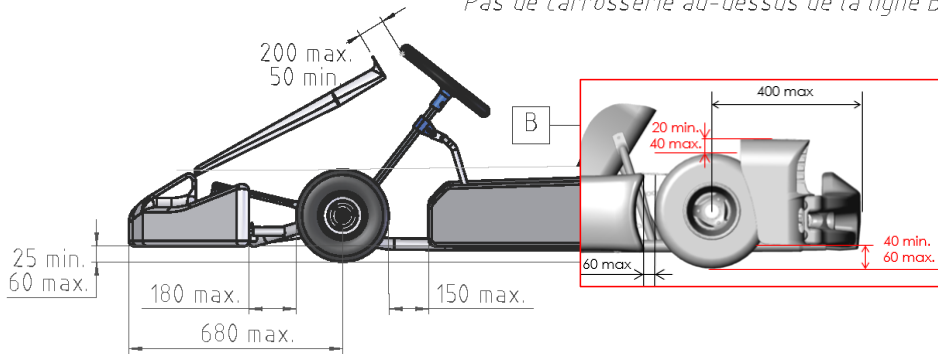

La distance maximale entre le bord supérieur central du panneau avant et le bord du volant en son point central ne doit pas dépasser 200 mm.
La mesure doit être effectuée avec le volant en position droite.

The maximum distance between the upper centerline of the front panel and the leading edge of the steering wheel at its center point must not exceed 200 mm.
The measurement is to be conducted with the steering wheel in a straight position.

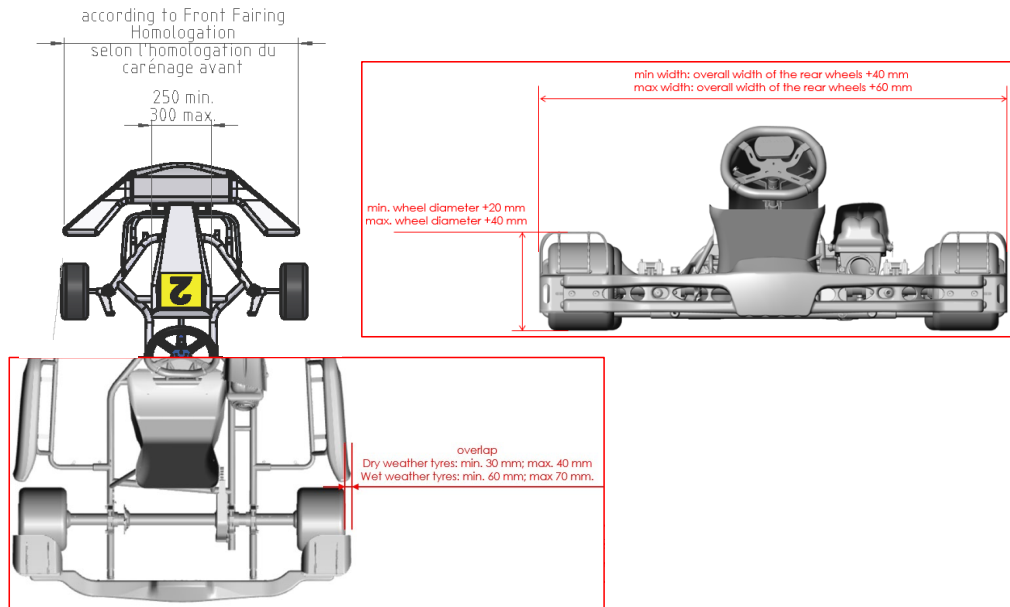

Bodywork Specifications for Mini

DESSIN TECHNIQUE N°3.1

Carrosserie - Groupe 3

TECHNICAL DRAWING No. 3.1

Bodywork - Group 3

No bodywork above line B /
Pas de carrosserie au-dessus de la ligne B

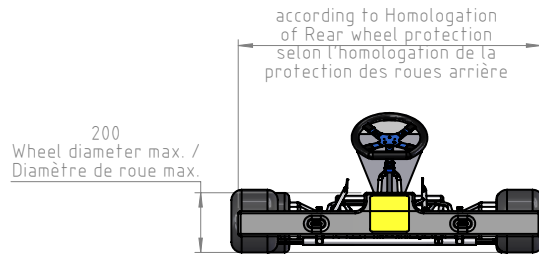
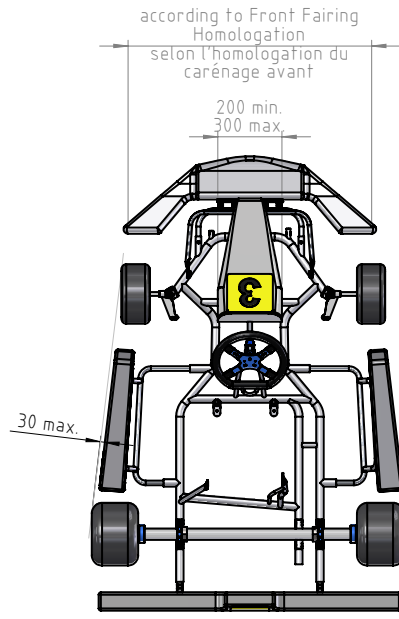
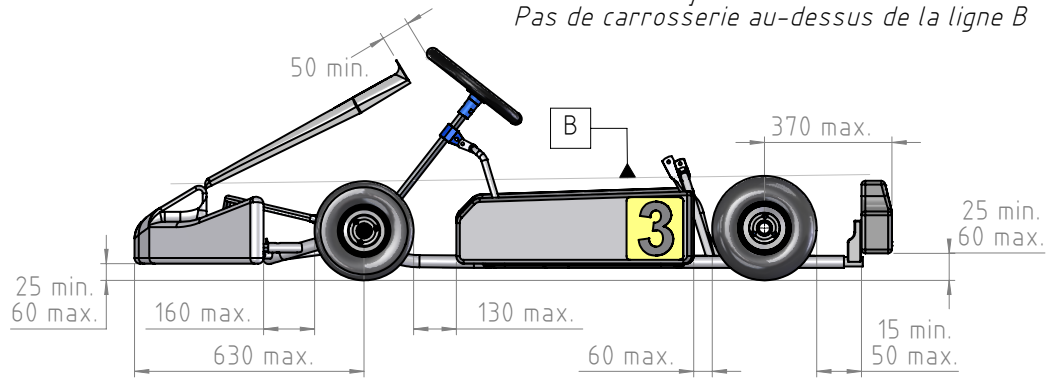

Minimum: Wheel in line with side bodywork and rear wheel protection /
Minimum: Roue alignée avec la carrosserie latérale et la protection des roues arrière

Dry race /
Course par temps sec

Wet race /
Course par temps de pluie

Cotes en/Dimensions in mm

DESSIN TECHNIQUE N°3.1b

TECHNICAL DRAWING No. 3.1b

Carrosserie pour circuits courts - Groupe 3 et Protection des Roues Arrière avec Boucliers de Roue

Bodywork for short circuits - Group 3 and Rear Wheel Protection with Wheel

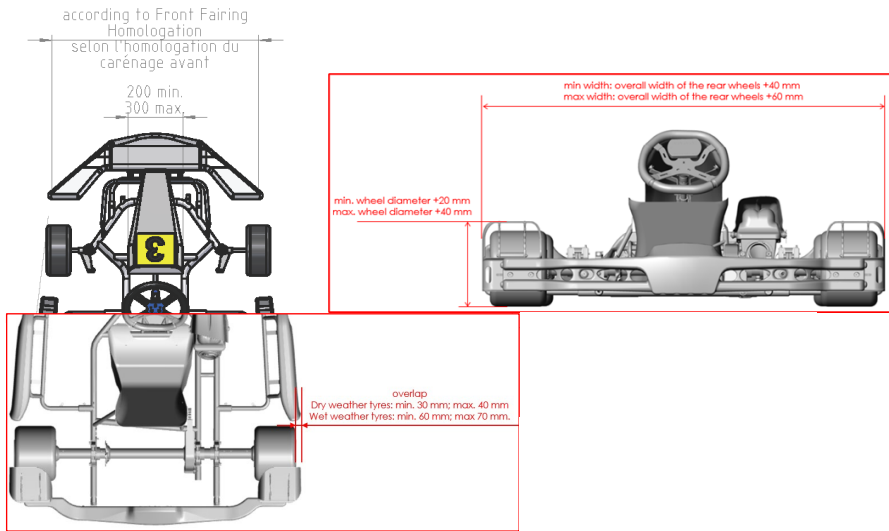
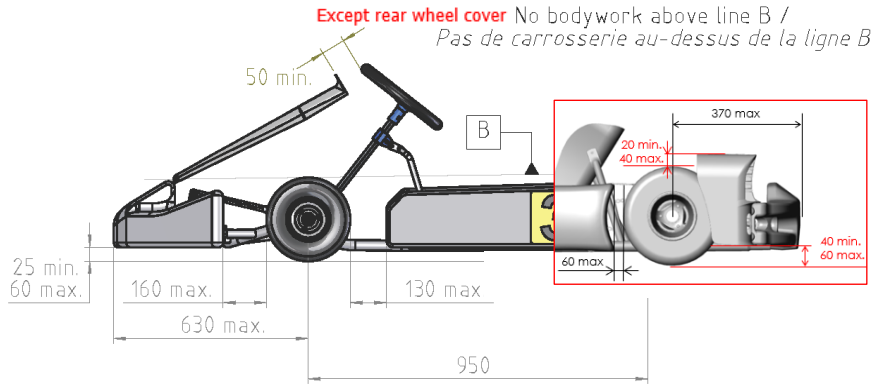

Cotes en/Dimensions in mm

Cotes en/Dimensions in mm

13. Ballast Weight Mounting

Ballast weight must be securely attached to the main Kart frame or seat. Mounting of ballast weight on bumpers or side bumper bars is not permitted. Bolts must be used to secure the ballast weights.

Attaching bolts must be no less than 5/16" (8 mm) in diameter.

A minimum of one attaching bolt is required for each 5 pounds of weight added. Attaching bolts must be securely fastened with one of the following methods:

Single nut with cotter pin or safety wire
Double nuts or Self-locking nuts – metallic or plastic type **with threads extending beyond the nut.**

Large area washers must be used in the attaching of weights to the seat of the Kart, both inside the seat and outside of the ballast.

14. Fuel Tank and System

The fuel tank must be securely fixed to the chassis and be designed in such a way that neither it nor the fuel lines (which must be flexible) present any danger of leakage during the competition.

Fuel line length is limited to a length sufficient to connect the fuel tank to the fuel pump and the fuel pump to the carburetor.

A quick attachment to the chassis is strongly recommended.

The tank shall in no way be shaped to act as an aerodynamic device.

The tank must supply the engine only under normal atmospheric pressure (this means that, apart from the fuel pump located between the fuel tank and the carburetor, any principle or system, mechanical or not, which may have an influence on the internal pressure of the fuel tank is forbidden).

It is mandatory to place the tank between the main tubes of the chassis-frame, ahead of the seat and behind the rotation axis of the front wheels.

15. Clutches

Dry, centrifugally operated engine mounted clutches are mandatory in all four-cycle classes.

16. Chain/Oil Guard

Chain driven Karts must be equipped with a robust chain/oil guard (see example on right).

The guard should be constructed of metal or plastic material, and securely mounted so as to not fall out of line with the chain.

The guard should extend around the axle drive sprocket to at least below the horizontal centerline of the sprocket and must cover the chain as viewed from directly above.

Loosely mounted guards tied to the chassis may not be accepted.

A chain/oil guard which is not in its proper position during a race may cause the entrant to be given a mechanical defect flag, at the discretion of the Race Director and/or the Steward(s) and/or the Technical Inspector if it is considered a hazard.

If a chain/oil guard is noticed to be improperly positioned, or is improperly fastened, on a Kart other than during a race, the entrant will not be allowed to compete until it is repaired.

Fully enclosed chain guards, shown on right, are recommended.

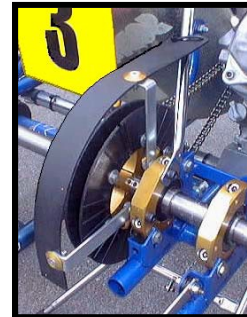

16.1. Chain Oilers

Chain oilers are not permitted.

16.2. Changing Ratios

Transmission, gearbox, differential, torque converter or other device that permit a change of drive ratio while the vehicle is in motion is not permitted, unless otherwise specified.

17. Competition Numbers and Number Panels

All competitors must use solid numbers on a bright yellow background. The number shall be bordered by the contrasting background by 1 cm minimum.

In each class each kart must have a unique number with a maximum of three digits (0 – 999) made up of numerals (1, 2, 3 etc.) only. No letters (A, B, C etc.) will be allowed.

Each numerical digit must be at least 15 cm (6-inches) high with a 2 cm (3/4-inch) thick stroke using an Arial type or similar font.

Four number panels with numbers must be displayed on each kart.

One located at the front/center of the kart, the numbers visible from the front, either mounted on the front bumper or the front panel.

One located on each vertical side pod/panel, as close as possible to the rear wheels.

One located on the rear of the kart visible and readable, from a position behind the Kart.

If number plates are used they must have rounded corners (diameter of rounded corners 15 to 25 mm), be flexible and made of opaque plastic. They shall always be visible (fixation without a possible displacement).



18. Instrumentation and Communication

- a) Definition of Data Acquisition: Any system, with or without a memory, installed on a Kart, enabling the driver or their team during or after an on-track session to read, indicate, acquire, record or transmit any information.
- b) Definition of Telemetry: Data transmission between a moving Kart and an external body.
- c) Data acquisition during qualifying, heats and races is limited to systems with or without memory that permit the reading of only the following parameters: engine revolutions (by induction on the spark plug HT cable), two indications of engine temperature, the speed of one wheel, one x/y accelerometer, lap times, engine hours, global position satellite sensing. Systems capable of more than the specified input channels must have all channels other than those allowed disconnected or disabled.
- d) Any system of telemetry is forbidden for the entire event.
- e) Any radio, electronic, or verbal communication between any driver on the track and any other body is forbidden.
- f) Beacons used only to trigger on-kart systems are not considered telemetry and may be used. They must be placed in a location as directed by the Race Officials.
- g) Track strip sensing devices are not considered telemetry when used solely as a trigger for Official timing and scoring, and/or personal on-kart lap timing.
- h) The power supply for Data Acquisition Systems may come directly from an onboard battery in classes that allow or require an onboard battery for starting the kart.

19. Throttle Return Spring

All karts must be equipped with a positive acting throttle return spring.

20. Seat Belts and Mirrors

Seat belts, rear view mirrors or driver restraint systems (seat belts) are prohibited.

21. Hand Controls

On application to ASN or the karting organization having jurisdiction, permission may be given for the fitting of brake and throttle hand controls.

22. Transponder

Competitors are responsible to purchase their own transponder mount that attaches the transponder to the kart. Mounts are available at most tracks.

For all practice, qualifying and race sessions, it is the responsibility of the driver to assure that an event-registered AMB-compatible transponder is fitted prior to entry to the track.

It is recommended that competitors purchase their own transponder.

If a time is not recorded due to transponder failure, if the transponder is not installed or is lost while on track, no other source of times is allowed to be used.

23. Transponder Mounting Location

The competitor is responsible for securing the scoring transponder to the kart to prevent loss of the transponder. The transponder must be mounted on the center of the rear of the driver seat. Minor offset from the center of the seat is permitted.

The transponder must be mounted vertically (inscription readable normally) with the center of the transponder installed 25 cm +/- 5 cm from ground level.

The space, in a straight line, between the transponder and the ground must be free, i.e. no lead, chassis tubing, battery or other element which can block the signal between the transponder and the detecting loop.

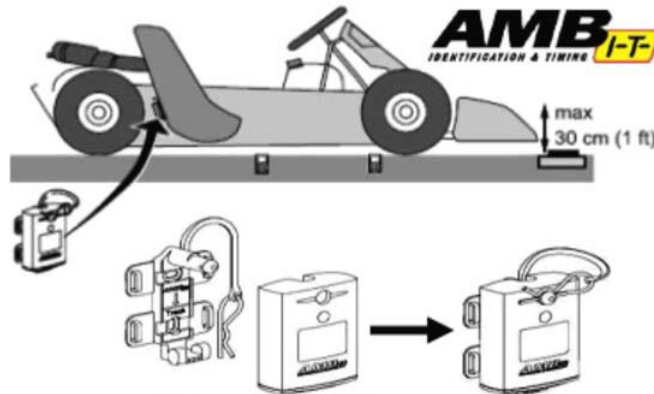

24. Driver's Name

It is recommended that the driver's name with the Canadian flag be on each side of the kart on the vertical portion of the side bodyworks. It is recommended that the height of the black letters of the driver's name and the flag shall be 3 cm minimum on a white background.



25. Starter Batteries

In classes that allow or require an onboard battery for starting the kart the specified battery must be mounted in the kart at all times. Only sealed, leak proof (maintenance free) batteries are allowed to feed the starter.

26. Airflow Control on Radiators

If tape is used, each tape strip must be continuous and wrap totally around the radiator either horizontally or vertically. Tape may not be removed while the kart is on track. No pull-off tabs allowed. Adjustable Radiator Screens can be used instead of tape. 3D printed flat screens may be used provided they are firmly fixed to the radiator. See Canadian Rotax Max Challenge Regulations for Rotax classes.

27. TIRES

27.1. Tire Specifications

ASN or karting organization having jurisdiction reserves the right to designate specific tires, with regard to manufacturer name, size, and manufacturer designation, etc.

Tires in competition and practice must be pneumatic, designed for racing applications only. Radial tires are not permitted.

Maximum bead diameter is 5.0 inches.

Maximum outer diameter of all tires: Front 280 mm, Rear 300 mm. Minimum outer diameter of all tires is 225 mm.

Tires used must be CIK-FIA homologated unless specified otherwise in the Supplementary Regulations.

Any modification of a tire is forbidden. The treating of any tire with any chemical substance or by temperature alteration is forbidden.

Wet and Dry tires may not be mixed on the kart during any on track session.

Rear tire sizes must be used only on the rear of the kart. Front tire sizes must only be used on the front of the kart.

27.2. Tires for Use in Dry Track Conditions

a) Rotax Classes:

According to the Canadian Rotax Max Challenge Regulations.

b) All Other Classes:

For Qualifying, Pre-Final and Final races, competitors may only use one set of four dry tires.

27.3. Tires for Use in Wet Track Conditions

a) Rotax Classes:

According to the Canadian Rotax Max Challenge Regulations.

b) Other Classes:

For Qualifying, Pre-Final and Final races, competitors may only use one set of four wet tires.

28. LOOSE OR LOST COMPONENTS

All major bodywork components, rear protection, bumpers and chain guards shall remain in their normal position throughout the competition.

Loose bodywork including side pods, front fairings (front fairing and steering column), rear protection, bumpers, chain guards or heat protective wrapping on a 4-cycle header/silencer may result in a kart being shown the BLACK flag with ORANGE DISK with kart number if judged by officials to be a hazard. A penalty may be applied even if the BLACK flag with ORANGE DISK cannot be displayed.

Loss of bodywork including front fairings (front fairing and steering column), rear protection, bumpers, chain guards, intake silencer on a 2-cycle kart or 4-cycle header/silencer will result in a kart being shown the BLACK flag with ORANGE DISK with kart number. A penalty will be applied even if the BLACK flag with ORANGE DISK cannot be displayed.

29. CIK-FIA including KZ, KZ2, OK, OK-N, OK-Junior, Mini, Superkart, E-Karting

Inspected according to CIK-FIA regulations available at <https://www.fiakarting.com/page/home>

30. Rok including Rok Micro, Mini, GP, VLR, Shifter

Inspected according to Rok Technical regulations available at <https://rokcupusa.com/rules/rok-cup-usa-series/>

31. Rotax including Senior Max, Junior Max, DD2, DD2 Masters, Mini Max, Micro Max

Inspected according to the Canadian Rotax Max Challenge Regulations available at <http://maxchallenge.ca>

32. Briggs & Stratton

Refer to Briggs & Stratton Racing Engines 2026 206 Factory Rule Set available at <https://www.asncanada.ca>

33. ALL OTHER CLASSES

Any other class not specified in these regulations will be inspected according to the official and accepted regulations published for that class or as specified in the Supplementary Regulations.

34. FUEL AND OIL REQUIREMENTS

Two-cycle classes may only use the fuel and lubricant oils as specified in the supplementary regulations. No additives are permitted.

Four-cycle classes may only use the fuel as specified in the supplementary regulations. No additives are permitted.

Samples of fuel, lubricant oils and crankcase oils may be requested at any time by the Technical Inspector for testing.

The Event Organizer may specify the use of ANY accepted method to determine fuel or oil legality including laboratory testing.

Hazardous and carcinogenic additives are prohibited from being added to competitor's fuel. This includes PowerMist Nitro X or PowerMist Nitro X2, Keyser's Pro Blend CTX2 and similar products.

Hazardous and carcinogenic additives are extremely dangerous if inhaled or if there is skin contact by participants at events including drivers, crew members, spectators and officials.

Use of these additives may violate the Canadian Environmental Protection Act (CEPA), Hazardous Products Regulations (HPR) and Transportation of Dangerous Goods (TDG) Regulations.

Any participant including drivers, mechanics or teams possessing or using any hazardous chemicals or products will receive an immediate suspension of their competition licence and an indefinite ban from participation in any form of kart racing in Canada.

Governmental or law enforcement authorities having jurisdiction may be informed of the possession or use of hazardous chemicals or products by participants.

35. TWO CYCLE FUEL AND OIL REQUIREMENTS

35.1. Source and Communication

Two-cycle classes may be required to use fuel for their specific classes, purchased from a specific source, for each sanctioned event. Communication of source shall be by bulletin at registration on the day of the event, and/or by Supplementary Regulation for the event.

35.2. Lubricant Oils

The chosen oil must be stated on the Competitor's entry form and declared by the competitor on the Pre- Technical Inspection Self-Declaration form. Any class may have a brand of oil specified for use in the Supplementary Regulations.

36. FOUR-CYCLE FUEL REQUIREMENTS - GASOLINE TO BE USED

Four-cycle classes are required to use PREMIUM UNLEADED gasoline with a minimum octane rating of 91 obtained from a specified location for each event. The source shall be stated in the Supplementary Regulations and publicized at registration.

37. FUEL AND OIL TESTING

Fuel and oil testing at an event does not follow procedures or standards of laboratory testing.

37.1. General Conditions

Competitors are NOT entitled to a race fuel or oil check at any time, either for themselves or another competitor.

A fuel check may be taken at any time during the event, from any part of the fuel system.

A sample of engine lubricating crankcase oil may be requested at any time by the Technical Inspector. The Event Organizer may specify the use of ANY accepted method to determine fuel or oil legality.

37.2. Fuel Checking Procedure

When using a conductivity sensitive fuel probe, normal procedure is to dip the fuel tester probe into the competitor's fuel tank at any time during the entire event, to determine if the Competitor's fuel is within specification.

A test sample may be taken from the fuel line to the carburetor into a glass bottle and tested when:

- a) There is insufficient fuel in the tank. Insufficient fuel to test is defined as less than 10 fluid ounces.
- b) There is insufficient access to the tank.
- c) The fuel level cannot be seen in the tank.
- d) Any other reason determined by the Technical Inspector.

Any additional test for gasoline and/or oil that is deemed acceptable by the Technical Inspector shall be admissible (i.e. specific gravity-hydrometer, additives-water test, chemical testing procedures etc.).

- e) Water Test for Four Cycle Fuel. In a clean glass bottle add half fuel and half distilled water. A legal sample will mix and become clear almost immediately. If the sample turns milky or is contaminated by foreign material it is considered illegal.

Decisions regarding fuel legality are not subject to protest or appeal.

37.3. Flame Test Procedure for Four Cycle Oil

- a) Drain about one 30 ml (1 fluid ounce) of oil into a large steel spoon or ladle.
- b) Apply heat to the bottom of the spoon with propane torch while checking the surface temperature of the oil with an infrared temperature gun.
- c) When the oil temperature is between 120 degrees C (250 degrees F) and 150 degrees C (300 degrees F) maximum, pass the flame 3 times over the oil approximately 2.5 cm (1 inch) above the surface. Do not touch the flame to the surface of the oil.
- d) If the oil ignites and continues to burn when the flame is removed, it is illegal. If the oil flashes and goes out, immediately when the torch is removed, the oil is legal.

Modifications of this method are acceptable if the following points are observed: Oil temperature never exceeds 150 degrees C (300 degrees F). The flame source does not touch the surface of the oil. Continued burning of the oil is necessary for illegality.

38. USE OF CAMERAS ON KARTS

The cameras listed below are the only cameras recommended for mounting on a kart.

 <p>GoPro Hero, 2, 3, 4, 5, 6, 7, 8, 9, 10, 11, 11 Mini, 12, 13, Session, MAX, MAX2</p> <p>http://gopro.com</p>	<p>Mount with GoPro GRBM30 Mount Kit</p> 	
 <p>Drift GHOST</p> <p>http://driftinnovation.com</p>	<p>Compatible with Drift Rollbar and Handlebar Mount</p>	
 <p>VIRB</p> <p>https://www.garmin.com/en-CA/</p>	<p>VIRB Adjustable Mounting Arm Kit Compatible with GoPro mounts</p>	
 <p>Aim SmartyCam</p> <p>https://store.aim-sportline.com/en/14-cameras</p>	<p>Preferred mount GoPro GRBM30 Mount Kit</p> 	

Two cameras can be mounted on a kart at any time.

Cameras must be clearly marked with the driver's name and kart number.

It is not permitted to mount a camera on a driver's helmet, plastic rear protection, side pods or front fairing at any time.

Cameras may be mounted on the front panel, rear of the seat, on a seat strut or a radiator mounting strut. Cameras cannot be mounted higher than the top of the steering wheel. No camera should block the view of the kart number.

Camera mounting must be by secure mechanical means only. All cameras must be tethered to the kart frame not to the camera mount or any other mounting bracket with a multi-strand cable.

It is not permitted to install a camera using any form of adhesive mounting material.

"In-helmet" cameras that are mounted to the interior of the helmet or near the viewport are not allowed.



The mounting position on the front panel is fixed horizontally, in the middle axis, and a minimum 10 cm below the bottom edge of the number area of the panel. The camera should not block the view of the number from the front.

The camera must be mounted using only mechanical mounting fasteners.



The preferred secure mechanical mount mechanism is the saddle portion of GoPro GRBM30 Roll Bar Mount kit shown by the red arrow on the left.



The GoPro camera mount hardware attachment to the front panel is as shown on the left. The same mechanical mounting method is able to be adapted for use with most cameras.

- 1 camera housing with support
- 2 M5x16 screws
- 2 washers
- 2 self-locking nuts

Loss of Camera

\$250 fine, loss of fast time in qualifying, 3 second time penalty in a race. Lost cameras will not be returned to the competitor until after the event.